



CREATING
VALUES
FLAT FILM AND
SHEET LINES

Extruder



SmartSheets®





KUHNE Maschinenbau GmbH

More than 85 years of experience

The extruder development of KUHNE GmbH goes far back to the year 1949. Out of the disorders from the second world war, resulted the first approach to design and build a machine, able to melt plastic. An old drilling machine was used to for the prototype of the extruder by putting a cylinder on top instead of a standard tool. Resulting from this were the first, pure extruders, mainly for profiles and tubes out of PVC, but from 1952 onwards also the first lines for sheet- and blown-film.

In 1959, Werner Battenfeld took over the extrusion facilities in Siegburg and integrated them into his worldwide operating company. The brand "Battenfeld" was worldwide known and famous for injection machines, extruders and textile machines.

The first General Manager of the Battenfeld extrusion site was Walter Kuhne, who continued to develop the extrusion technology for Battenfeld. By end of the sixties, the fast growth of the group led to serious financial problems, giving Walter Kuhne the chance to use a Management Buy Out in order to get possession of the Battenfeld extrusion facilities and to rename the company into KUHNE GmbH.

In the following years, KUHNE GmbH concentrated on the production of blown- flatfilm and sheet lines. One of the first blown-film lines was already built in the early fifties, so that approximately twenty blown film lines per year were delivered worldwide by the future KUHNE staff.

Already in the year 1956, sheet lines for the production of PC have been delivered – also first tests with PE-sheets have been realized. In the thermoforming business, still young at that time, first machines were sold in the sixties for the production of PS and PVC.

In the seventies, KUHNE GmbH developed for example the first coextrusion-line for milk and stripes film, where up to four extruder produced different colours side by side into one blown film.

An additional milestone for KUHNE was reached by placing HDPE-extrusion-lines in the market in the eighties. More than 500 of these lines were sold. In the same period, a significant amount of PS- and PP- Inline-machines were sold to dairies and their suppliers. In the sheet sector, the first huge lines with working widths up to six meter and thicknesses up to 50mm were developed, sold and delivered.

The nineties for KUHNE were dominated by huge co-extrusion blown film lines as well as the ongoing development regarding multi-layer feedback systems for flat film and sheet lines. Outputs were raised and layer thicknesses more and more reduced; in the same time tolerances minimized.

From the year 2000 onwards, the number of delivered blown film lines and machines for five and seven layer has been rising. In Flat film extrusion, KUHNE presented the High Speed concept – a system that almost doubled outputs. Another highlight in sheet extrusion have been numerous lines for the production of tanks for the automotive industry. The needed tank sheets have been extruded, welded and used in the cars of worldwide known producers.

The new millennium brought among other things High-Speed Extrusion, many barrier- and sheet lines and the market leadership in huge geomembrane lines.

1972

Construction of the first line for the production of sheets out of high-molecular HD-PE and PP

1980

KUHNE supplies Turnkey-ready factories including extrusion

1990

KUHNE supplies a flat sheet line in 6.300mm width for landfill to South America

1997

KUHNE presents the first aluminium-composite-sheet line
Construction of the first 8-layer feedblock (bolt design)

1949

Development of the first extruder HKS 80/60

1970

Dipl.-Ing. Walter Kuhne takes over the whole company Battenfeld Siegburg

1975

KUHNE GmbH moves from Siegburg to the new production site in Sankt Augustin

80s and 90s

Delivery of numerous Inline Coextrusionlines (up to 7-layer) – mainly within Europe

2002

Presentation of the High-Speed-Extruders KHS 60 and 70

2004

KUHNE presents the first PMMA sheet line for the production of displays

1934

Foundation of the mechanics company Heinrich Koch

2011

KUHNE supplies a coextrusion twin-screw-line for the production of PET-sheet without pre-drying and PE-inline-lamination
Delivery of the 50th KUHNE-Extruder with Torque-(Direct-)drive

2020

3 new Orders for Geomembrane Lines for 3 different continents

2019

Installation of the already 8th high-speed inline machine since 2011 at a known producer in France. For PP coextruded films up to 800kg/h output

KUHNE presents the High-Speed Extruder KHS90

2012

KUHNE Maschinenbau receives order for a 7500 mm wide Extrusionline for the production of geomembrane films for Northern Africa

Delivery and successful installation of 9-layer lamella-bolt-feedblock

2018

Delivery of the 25th Inline – Barrier Line for coffee / tea capsules with KUHNE lamella feedblock

Delivery of the already 7th line for the production of ABS / PP edge bands for the furniture industry within only six years

New order for the 6th sheet line for the production of ABS sheets within two years for the automobile and kitchen industry

2017

Installation of a 9-layer sheet line to Middle East for high-barrier packaging out of PS and PP. Throughput 1,5t/h, net width up to 1.500 mm

Start up of another Geomembrane line – this time in Germany. 7.500 mm net width, 3,5t/h output in PE

2013

Additional huge order (8500 mm width) for a coextrusion line for Geomembranes for Saudi Arabia.

Delivery and installation of numerous PET film lines with different technologies such as twin screws, infrared drying or reactor systems



Highlights from 85 years

Many different, state-of-the-art applications in flat-film and sheet are produced on KUHNE-extrusion-lines:

- Food packaging/barrier foils (margarine, drink cups, yoghurt cups, meal trays, microwave trays, coffee & tea capsules) MAP, FFS
- Medical packaging (barrier foils)
- Stationary foils (folders, index foils etc.)
- Collapsible box, display foils and sheets
- Fibre-reinforced laminated foils, insulating films and tarpaulins
- Smooth or embossed foils and sheets for automotive application
- Optical application
- Sanitary application
- Advertising industry
- Plastic container production
- Edge bands for the furniture industry
- Geomembrane Films

Our Divisions: Flat-Film and Sheet-Lines

Modern Packaging – ecologically compatible

Packaging out of plastic is a decisive contribution to environment protection:

- Protection for packed goods; minimized losses of for example food through transport and storage
- Light weight, energy savings during transport, no energy required by empties transport
- Low energy effort for the production
- Saving of drinking water, as the cleaning and rinsing procedures required in multi-way-systems are not necessary
- Suitable for chemical, material and thermal recycling

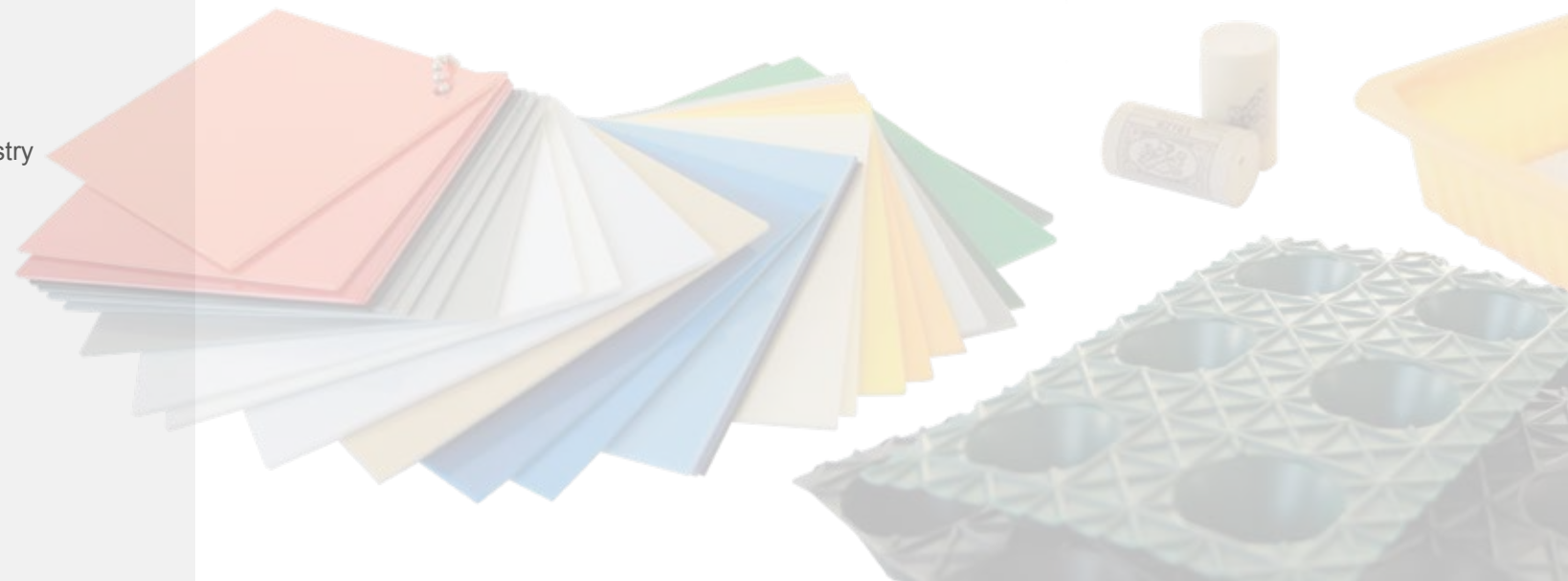

Flat Films

Sheets

PS-, PP- & ABS-
films

PC- & PMMA-
films

PET-
films

Special-
films

PE- & PP-
sheets

PS- & ABS-
sheets

PC- & PMMA-
sheets

Offline-
films

Inline-
films

Display/optical
films

Twin-screw-
extruder

Mono-screw-
extruder

- Barrier-
films
- textile re-
inforced films
- Direct
vacuum formed
films
- Lamination
process
- Geomembrane
films

Barrier-
sheets

- Multi layer
sheets
- Composite
AL / PE / AL
sheets
- Embossed
sheets

- Multi layer
UV/FR-sheets
- Embossed
sheets

- Multi layer
UV/FR-sheets
- Embossed
sheets

IRD-
drying

Hot air
drying

LSP-reactor
(liquid-state-
polyconden-
sation) for IV
recovering

further reactor
systems for
inline treatment
of material

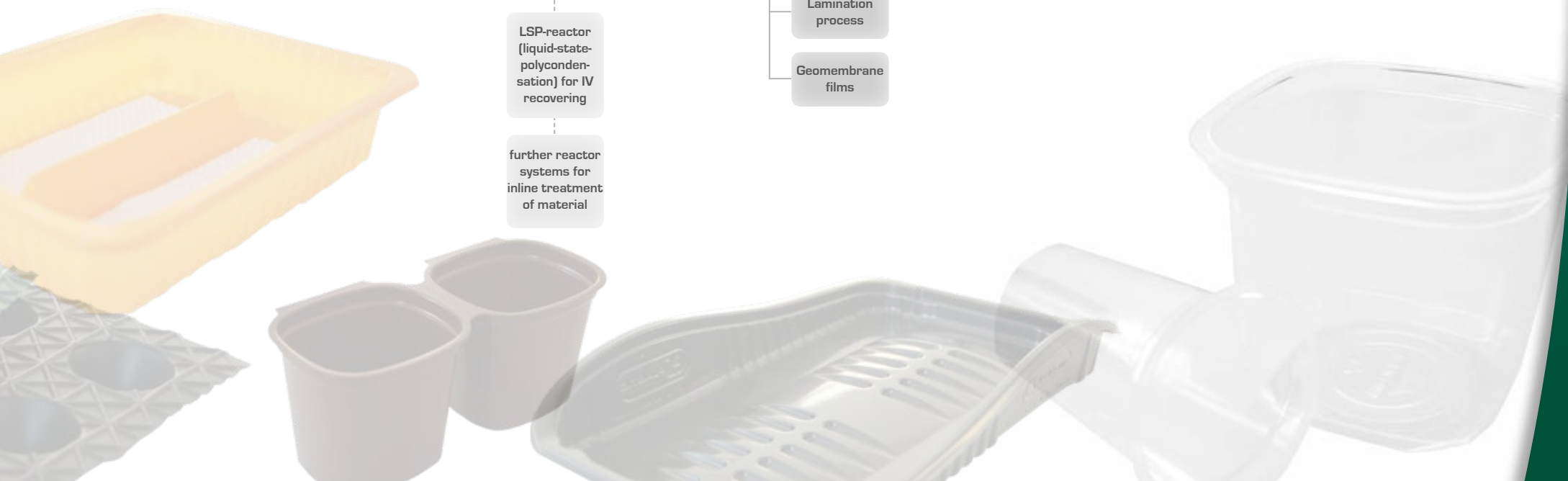



Extruder – It's all about the optimum geometry

KUHNE single screw extruders are efficient, economical and reliable plastification units, proven to handle almost all currently available thermoplastics. They are part of KUHNE turn key extrusion lines such as blown films lines, flat film and sheet lines, cast lines, profile lines, cable coating, recycling and compounding lines. There are more fields of application for KUHNE-extruders in other extrusion domains.

All thermoplastics such as granulate or regrind can be processed: for example all known polyolefins, ABS,

Polyurethane, TPE, PET, PP, PS, HIPS, PA, EVOH, PU, LDPE, HDPE, filler containing compounds such as PP with wood filler, recycled plastic, biodegradable polymers and high-temperature materials.

- Single screw extruder K25 – K250
 - K45 & K60 in modular principle and short delivery time
 - High Speed Extruder K60, K70 & K90
 - Option: complete housings L < 80 dB(A)
 - High temperature version up to 450 °C

- Screw diameter 25 mm – 250 mm, barrel length 24D – 44D
- 3-zone - screws, venting screws, barrier screws with shearing & mixing section
- Barrier screws for the processing without screw change

All KUHNE screws & barrels are based on inhouse designs & geometries. Experience and know-how of many decades help to make every extruder a better one.

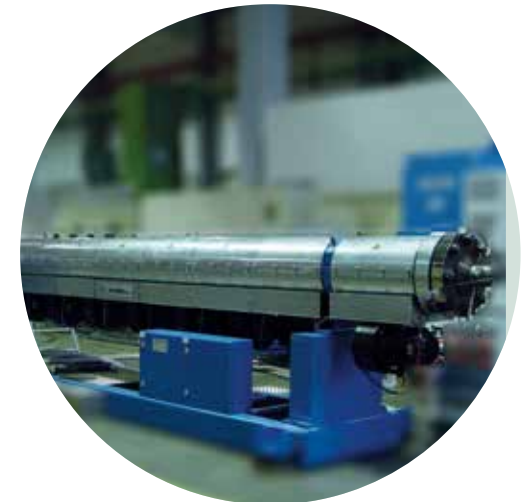



- Vented-screws (for hygroscopic polymers)
- Barrier Screws (for hygroscopic polymers)
- Screw removal to the back or to the front
- Barrels with double or fourfold venting available
- Barrels are gas nitrated, bimetallic liner (optional), with heat separation and grooved feed section, water- or oil-cooled.
- Smooth or grooved feed section
- Temperature controlled feed sections
- Output up to 3.500 kg/h
- Low maintenance A.C., D.C., direct drive with gear, torque drive without gear
- Visualization via display, central or decentralized placement of control cabinet



Extruder K25 bis K250

Barrel and screw design

Latest state of the art designs of barrels and screws guarantee highest output rates with homogenous melt at the same time. Each KUHNE-extruder screw is tailor-made and gets its individual geometry according to application and material. In order to achieve maximum life, nitride-hardened, armoured or special alloy screws are used.

Barrel

The extruder barrel – comprising barrel feed housing (2), exchangeable liners (3) and barrel feed section – is equipped with ceramic heater bands (6) plus cooling segments for high capacity cooling. The barrel length is 24, 30, 33 or 36D; vented extruders 33, 39 or even 44D. The feed section with feed housing (2) and the exchangeable liner (3) are a separate, modular part.

Screw removal

A special hollow shaft design allows the screw to be removed either to the rear or to the front. Removal of screw to the rear is recommended to avoid time consuming removal of downstream equipment.

Vented extruders

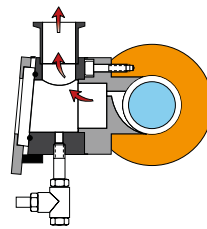

All extruders of the “E” series have a generously sized vented zone (8). Single, Double or even Four-fold venting zones available. Large quantities of moisture and monomers are separated and eliminated ecofriendly with low maintenance running vacuum pumps.

Drive and gear

The low noise solid gear of low noise transmits the torque to the screw via V-belt drive between motor and gear (1) to ensure the optimum adaptation to the screw speed. Today, KUHNE-extruders are more and more equipped with A.C. drives with inverters or permanent torque drives with highest energy efficiency.

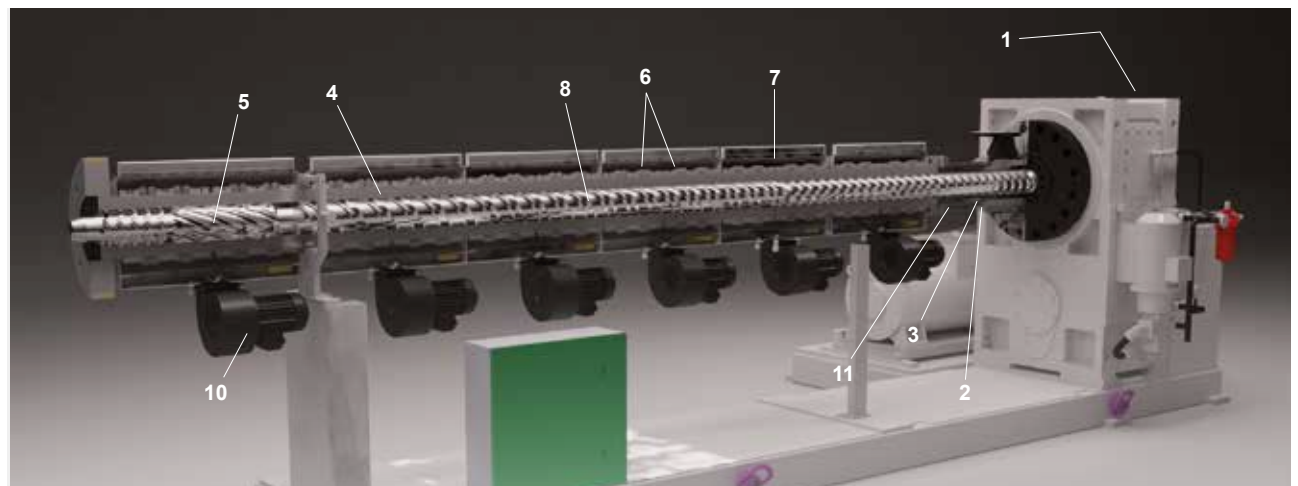

Extruder: 1 Gear with special hollow-shaft design, 2 Barrel feed housing, 3 Exchangeable feed section (smooth or grooved), 4 Barrel, 5 Screw, 6 Ceramic heater band, 7 Cooling segment, 8 Venting dome(s), (9 Vacuum unit), 10 Cooling blower, 11 Connection for heating and cooling units



Extruder Type K 45 - 24 D

KUHNE GmbH, is introducing a new extruder type named K45 – 24D neo, with components that have been reengineered to make standardized, but high performing extrusion that is **accessible for everyone**. Below are the general specs of the extruder and more can be provided upon request.

Technical Data:

Extruder Type:
K45 – 24D neo with 24/1 length diameter ratio

Maximum Output:
(depending on raw material grade & screw design)

Type	Kg/h	Lbs/h
PE-HD	100	220
PE-LD	120	264
PVC	80	175
PP	80	175
TPE	50	110
TPU	75	165



KUHNE roll stacks – precision counts!

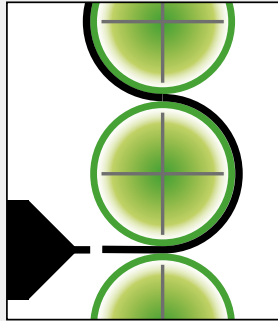

Vertical for PS, PP, HDPE, ABS

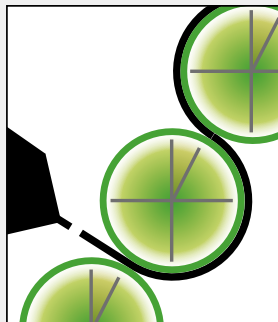

30° – 45° inclined for PMMA, PC, PET-
Movablesystems for top and lower roller

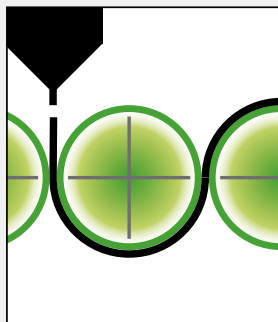

Horizontal for PMMA, PC, PET

The roll stack is the decisive element for a high-quality surface of the films.

An optimized tempering of the rolls in combination with the special hardened KUBI-rolls allows the both-sided polishing of films even below 400 my. According to application request, the roll stack can be executed vertically, horizontal or 30° inclined. Air knife integration instead of // in addition to the rolls for thin films.

- Width range from 600 to 10.000 mm
- Roller diameter from 200 to 1.000 mm
- Rollers individually driven
- Servo- and A.C.-drives for roll stack and haul off
- Individually cooled rollers with water or oil
- Adjustment of roll gap and roll positioning on both sides by servo drive
- Pressure optimized bending roll for PET applications
- Fast opening for quick roll change
- Movable top or bottom roll
- Hydraulic gap adjustment (with integrated measuring control) optional
- Production of thin films 120 my for PET & 200 my for PP possible

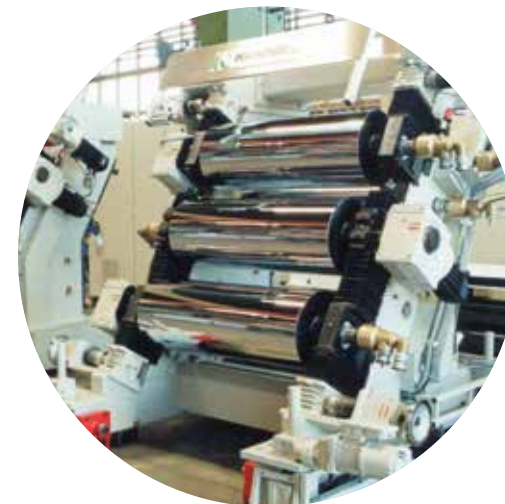

Automation, Control and Visualization – KEC KUHNE Extrusion Control

The management of data processing is based on a SIEMENS (S7-SPS) industrial PC TIA system. All production lines can be equipped with KEC-process control/visualization.

- All systems with touch panel control
- Visualization of all relevant process parameters; nominal and actual values
- Alarm system
- Recipe storage and management
- Control of the heating zones for different types of the die
- Storage and archiving
- Tracing, trends and curve charts
- Printouts and protocols
- Maintenance and service via teleservice/diagnosis
- Multiple language switch
- Visualization of process parameters of machine components of other suppliers
- Key Performance data can be visualized on smartphone or / and tablet

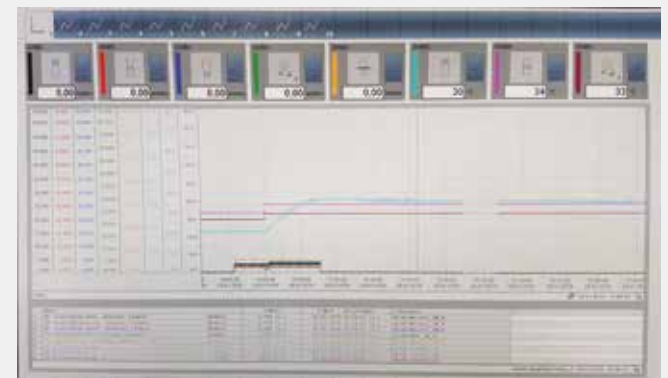



K-tool GmbH

K-tool is a daughter company of KUHNE Group. The company was founded 2010.

For more than 60 years, the crew of KUHNE Group has been producing flat sheet dies up to 9m width, multi-layer feedblocks of up to 11 layers, blown film heads up to 17 layers, extrusion screws, barrels, feeding zones and many parts more.

The company possesses a state of the art machine park with more than 35 staff members, that do not back down even in front of difficult challenges. If you are looking for highest quality and best competence – contact us.

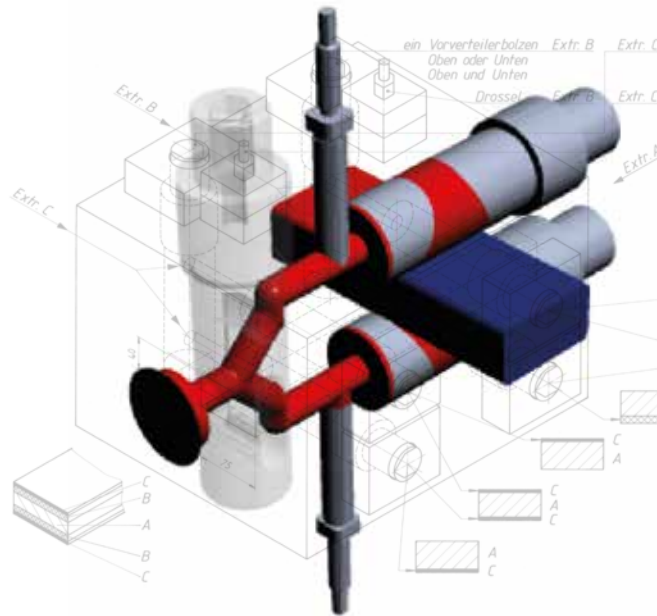
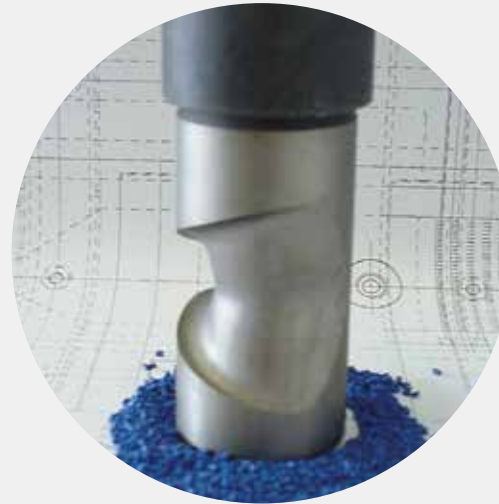

3/5-layer-feed-block-bolt-type

Short delivery time, modular principle

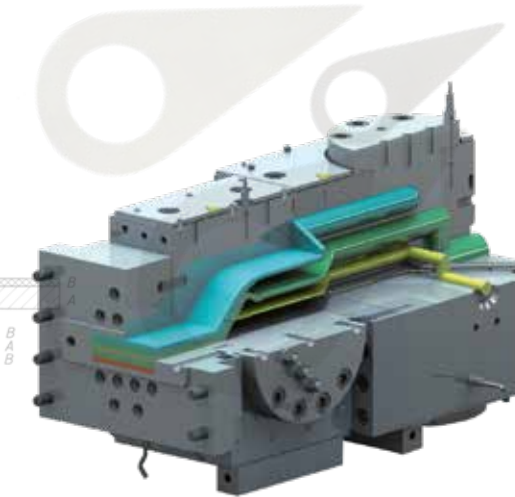

7-layer-feed-block-lamella-type

Thin middle layer (EVOH), edge capsulation, short residence time

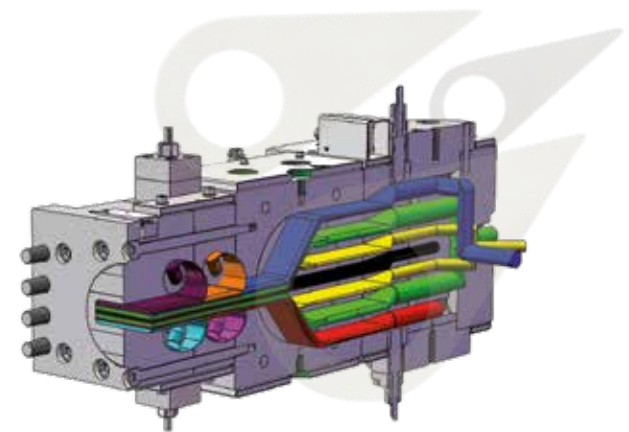

9/11-layer-feed-block-combined lamella/bolt-type

For asymmetric layer configurations & various products with different thicknesses

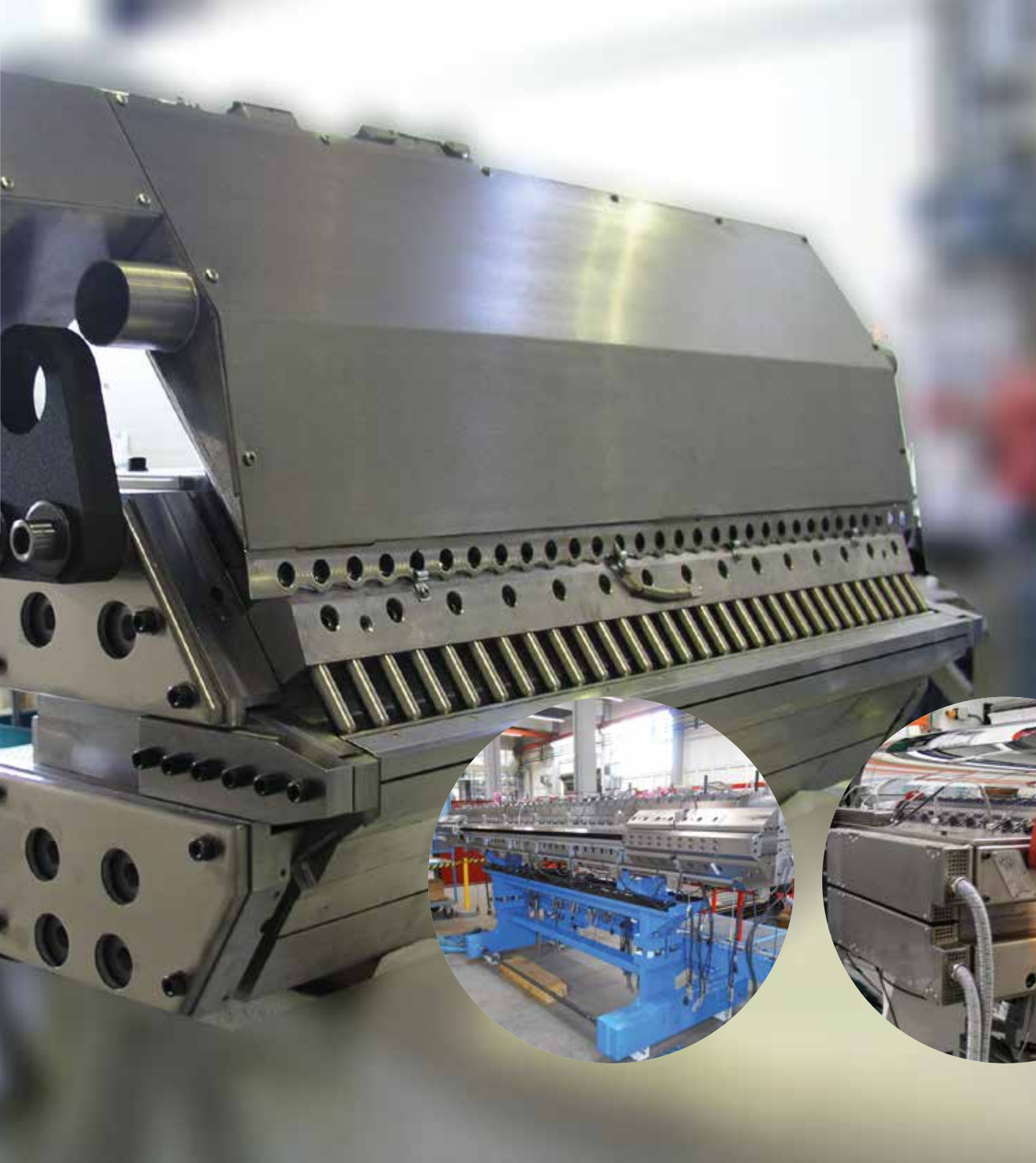

Flat dies

- Width range from 70 mm – 9.000 mm
- T-channel dies with integrated deckling
- Coat hanger dies with external deckling
- Multi-channel dies
- Fast gap dies
- Optimized feeding zone for the feed block coextrusion
- Optimized flow channel because of 3D-based design, with or without restrictor bar
- Restrictor bar to optimize flow behaviour
- Changeable flex lips
- Manual or automatic lip gap adjustment
- Deckling optional; internal or external
- Flexible lip gap 0,1 mm – 15 mm
- Sheet dies with lip gap 2 mm – 75 mm





Flat Films

PS-, PP-, PET &
ABS films

Offline-
films

Components:

- Dosing device
- Extruder
- Screen changer
- Melt pump
- Foaming system – for PS, PP, PET & ABS
- Static mixer
- Feed-Block-System, Bolts and Lamella
- Flat Film Die Manuell / Automatic
- Roll stack
- Roller conveyor
- Thickness measurement
- Inspection system
- Corona system
- Silicone application system & drying
- Edge cut
- Haul Off
- Accumulator
- Winding Unit

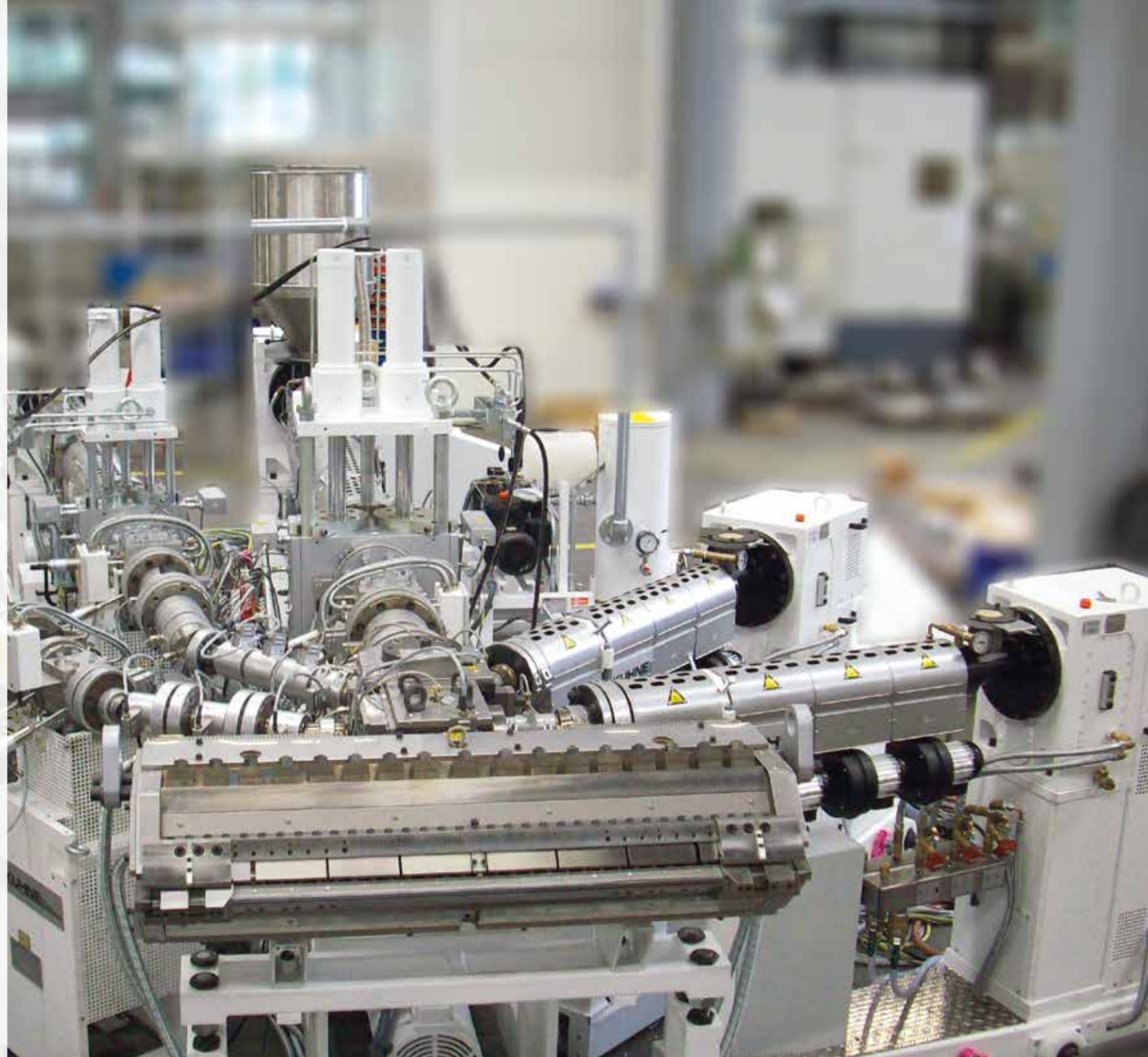

Sustainable concepts – high customer profit

The Inline principle stands for economic manufacturing and production

The Inline process is getting more and more interesting and economical. Up to now, the separate units are linked but with PLC interfaces it's possible to merge them to an installation operational and manageable from the resin to the ready product.

Depending on the lot size inline running is a real alternative compared to the offline process.

It's possible to run the line either according to the thermoforming machine to be the master towards the extruder or reverse - depending to the photoelectric loop control. Linked with the KUHNE-PLC, the line can be started with only one operator.

For the sustainable benefit of the customer the aim is to link extrusion, thermoforming, buffering and even printing. Here the important part is the editing and visualization of actual values and operating of all machine parts.

KUHNE developed its easy running concept with all noted suppliers of thermoforming machines.

Due to the use of the KUHNE-High-Speed-Extrusion-Technology and a special arrangement of the extrusion and thermoforming machine, it is now possible to quadruple the throughput per square meter of floor space requirement.



Flat Films

PS- & PP-
films

Inline-
films

High Speed Extrusion Lines Inline

- Torque-Synchrone or AC direct drive
- P = 110 to 495 kW
- ns1 = 450 to 1.000 min-1
- ns2 = 1.000 to 1.500 min-1
- Ø 60, 72 & 90mm
- Throughput:
up to 2.600 kg/h PS
up to 2.200 kg/h PP
up to 1.800 kg/h ABS
- Needed space four times less compared to standard lines

Thermoforming Lines – The product defines the machine

Flexible, modular line components

We are always focusing on highest efficiency, low energy costs and highest flexibility.

- Customer specific requirements can be realized
- Extruders are available in our lab – trials with customer raw material possible anytime
- Feeding and Dosing, Screen changers, melt pumps and winders of different types and suppliers can be integrated

High-Speed-Extrusion-Line KHS90EE-39D

- P = 495 kW @
- ns1 = 800 min⁻¹
- ns2 = 1.100 min⁻¹
- V max. = 5,18 m/s
- PPL max. = 2.600 kg/h PS
2.200 kg/h PP
1.500 kg/h ABS



**One layout – one design
– one price**

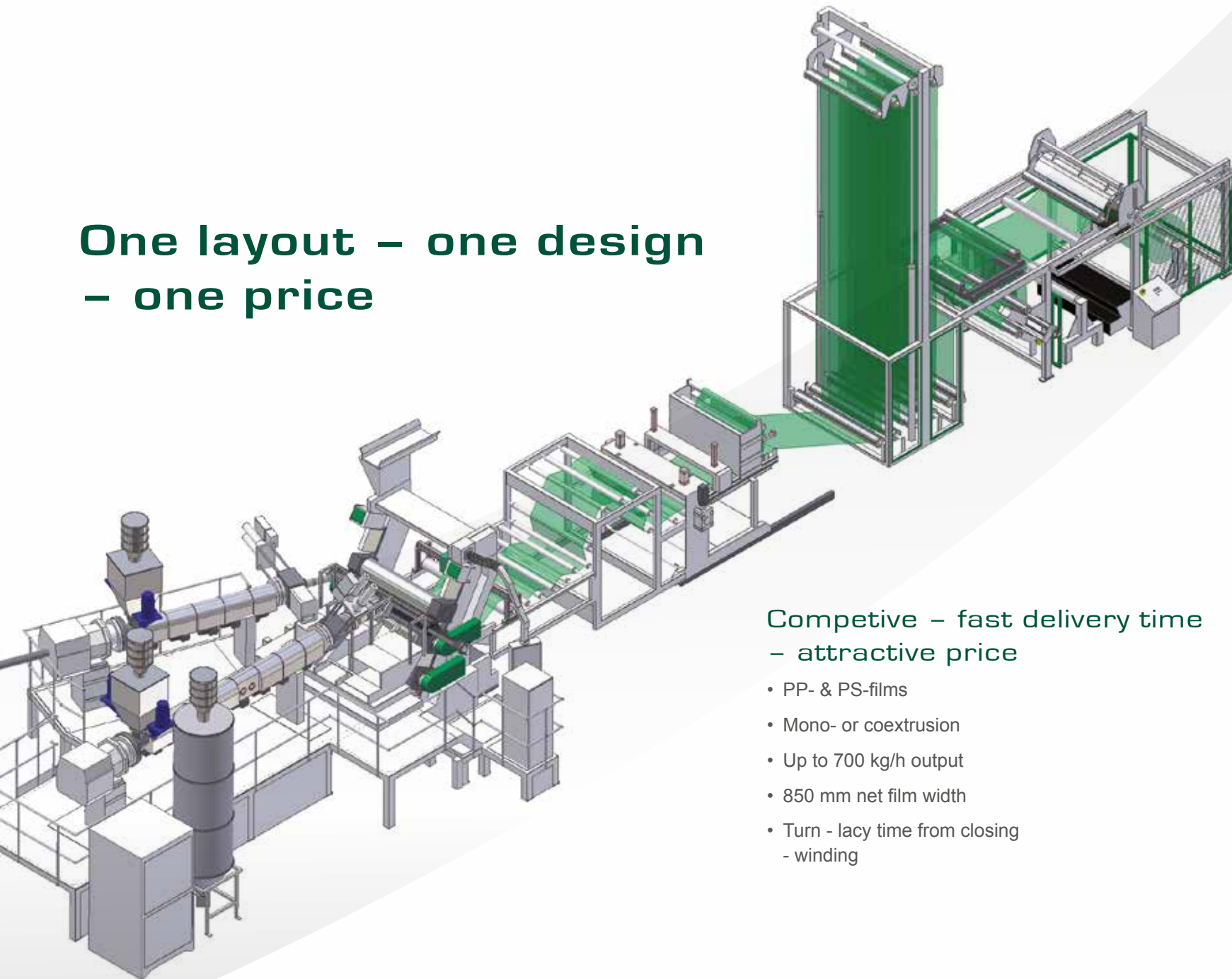

Flatfilms

**PS- & PP-
films**

**Offline-
films**

**Competitive – fast delivery time
– attractive price**

- PP- & PS-films
- Mono- or coextrusion
- Up to 700 kg/h output
- 850 mm net film width
- Turn - lacy time from closing
- winding



Twin screw extruder

PET concepts

PET-films have numerous advantages; for example high tear resistance, chemical, mechanical and thermal stability as well as transparency.

In addition to that, it is possible to directly transform PET In-house / Bottle Flakes or Post-Consumer materials into PET-Flat Films.

Economic efficiency and sustainability have raised the share of films with high percentage of regrind in the last years.

KUHNE-Smart-Sheets offers the possibility of Inline-Lamination PET-PE directly in the roll stack or with a laminator integrated in the line.



Horizontal KUHNE PET roll stack
with hydraulic roll adjustment



IRD drying

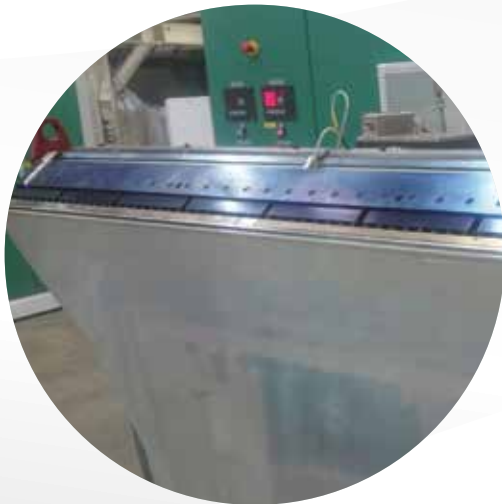

KUHNE PET T-channel die
with internal deckling

Flat Films

PET-films

You have PET – KUHNE has your solution:

- Output: 750 kg/h – 2.500 kg/h
- Width: 1.000 mm – 2.000 mm
- Thickness: 120 my – 1.8 mm
- FDA & EFSA-conformity
- Integration of different concepts such as: Twin screw extruder & reactor systems for control & increase of IV value
- KUHNE mono-screw-extruder with hot air pre-drying with IRD-drying

Flat films

Special-
films

KUHNE-specialfilms

Direct vacuum forming films (dimpled sheet)

- Foundation wall protection
- Planted, green flat roof sealing
- Engineering, building and tunnel construction

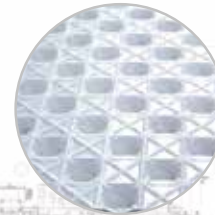
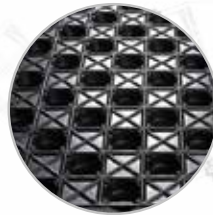

Fabric reinforced films (up to 5 m width without welding seam)

- Flat roof sealing
- Advertising banner
- Decorative scaffolding cladding
- Conveyor belts

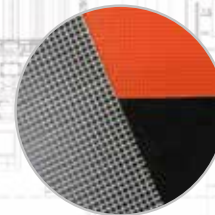

Geomembrane films

Geomembrane films are enduring, durable plastic sealing webs with smooth or embossed surface.

Typical for this kind of film is the very high resistance towards chemicals and other, various foreign matters.

The UV stabilized film is 100 % environmentally sustainable and has no negative effects on drinking water.



Applications:

- As isolation or sealing of areas and surfaces at the construction of landfills, chemical storage places, gasoline stations, parking lots etc., in order to prevent pollutions of ground water
- At the construction of lakes, as film for ponds and swimming pools
- As plant and/or root barrier
- Sewers, Dams, Mining industries



Geomembrane Lines

- Output from 1.000 kg/h up to 3.500 kg/h
- Width: 5 m, 6 m, 7 m, 8 m (net width)
- Thickness: from 0,5 mm up to 3 mm

KUHNE feedblock when coextrusion

KUHNE / K-tool die up to 9m width

Highly sophisticated rolls up to 1.000mm diameter

Worldwide best thickness tolerances up to +/- 1% by using energy saving die-tool

Individually designed spike-pattern with up to 2 Million spikes / roll

Sheets

Challenge us

Extruded sheets out of thermoplastics:

- up to 60 mm thickness
- up to 6.000 mm width
- up to 11 layers

Best energy input values per kg of extruded sheet.

Many decades of experience in all sheet applications.

KUHNE designs the machine according to the final product – and not reverse.



Sheet extrusion – from thin to thick – from transparent to high-barrier

Sheet lines for the processing of thermoplastics such as:

- PE – HD polyethylene high-density
- PP polypropylene
- SB polystyrol high-impact
- ABS acrylonitrile-butadiene-styrene
- PMMA polymethyl methacrylate
- PC polycarbonate

Mono- or multi-layer by means of Coextrusion, smooth or embossed. Width range from 600 mm up to 6.000 mm. Thickness range from 0,3 mm up to 60 mm; depending on application and raw material.

- One over the other roller conveyors
- Post cooling calibration roller conveyor
- Thickness measurement
- Corona Treatment
- Sheet inspection systems

- Lengthwise cutting done as:
 - knife cutting system
 - saw
 - mill
- Edge cutting recycling system in different versions
- Protection film lamination; one or both sides
- Haul Offs
- Cross cutting devices such as:
 - guillotine (also in combination with mill or saw)
 - saw
 - mill
- Sheet surface cleaning systems
- Stacker
 - gantry robot
- Machine parts can be fitted into clean room surrounding



All key components such as extruder, feedblocks, dies, roll stacks, roller conveyors and haul-offs being produced by and at KUHNE.



Creating solutions! Remote Lense – your direct path to the solution

- Connect your operator directly via Remote Lense with our experts at KUHNE
- Seeing the problem and at the same time showing it to us
- Complicated descriptions and unnecessary interventions can be avoided
- Dialogue is made with simultaneous translation in multiple languages or can be held in our written chat
- The active suppression of noise allows a very clear communication without disturbing background noise
- The exchange of data such as pictures, videos or electric drawings works easily in both ways
- With available WIFI, a transmission in HD quality is possible
- Only one avoided intervention of a technician already pays off the glasses



Keep everything clear
in sight with KUHNE:

The Remote Data Lense

Contact us anytime:
service@kuhne.de



OUR EXPERIENCE

SmartSheets®

IS YOUR FUTURE



Our service – your benefit

KUHNE SERVICE

Service at KUHNE Group offers his customers best possible solutions in the fields of spare parts, retrofitting, maintenance, trouble shooting – as well as start ups and trainings. Therefore, highly motivated and competent service engineers are at your direct and personal disposal.



✓ Tool service

- Exchange and cleaning of tools directly at your line
- Checking and expertise of all line components on the spot
- Complete cleaning of dies and blown film heads at K-tool; followed up by reprocessing for improved product quality

✓ Repair service

- Repair of screws, barrels, blown film heads and dies at K-tool
- Repair of all installed and used components by the manufacturer

✓ Spare part service

- Supply of original spare parts
- Dispatch of the needed parts on the same day with your order before noon

✓ Trouble shooting

- Intervention of our technicians possible within 24 hours
- Long distance diagnosis via Teleservice

✓ New trends and developments

- Continuous new technical developments and improvements by our technical staff and R&D engineers
- Such as: chrome platings, coatings, fuels and lubricants etc.

✓ Erection and start up of new lines

- Consultation with our customers before delivery in order to optimize the course of erection
- Start ups and test-runs

✓ Maintenance

- Tailor made maintenance concepts for complete lines or components
- Maintenance contracts; also long-term

✓ Training

- Machine maintenance
- Trouble shooting
- (optimized) operation of lines

✓ Retrofitting

- Modernization of your line for optimization of output, quality and changeover

✓ Move your line

- We dismantle, move and re-erect your line at the new spot. Including other brands and machine types

phone +49(0) 2241 902 0

fax +49(0) 2241 902 180

mail service@kuhne-group.com

more informations:

www.kuhne-mb.de/service



Advantages for our customers:

- Personal, direct and skilled care through our experienced contact persons
- Multi-language contact persons and service technicians
- Higher productivity and value retention through preventive maintenance and upkeep
- Use of original spare parts for fast and easy fitting
- Reduction of line Stops
- Prolongation of operational life span



CREATING
VALUES
FLAT FILM AND
SHEET LINES

KUHNE GmbH
Einsteinstraße 20
D-53757 Sankt Augustin/Germany
phone +49(0) 2241 902 0
fax +49(0) 2241 902 180
info@kuhne-group.com

www.kuhne-group.com



NORTH
AMERICA

1251 N. Eddy Street, Suite 200, South Bend, IN,
46617, USA

